

**2500 HP PUMPER**

**SPECIFICATION: PS-FP2500A**

**THE  
ULTIMATE PUMPER  
FOR THE MOST CHALLENGING JOB**

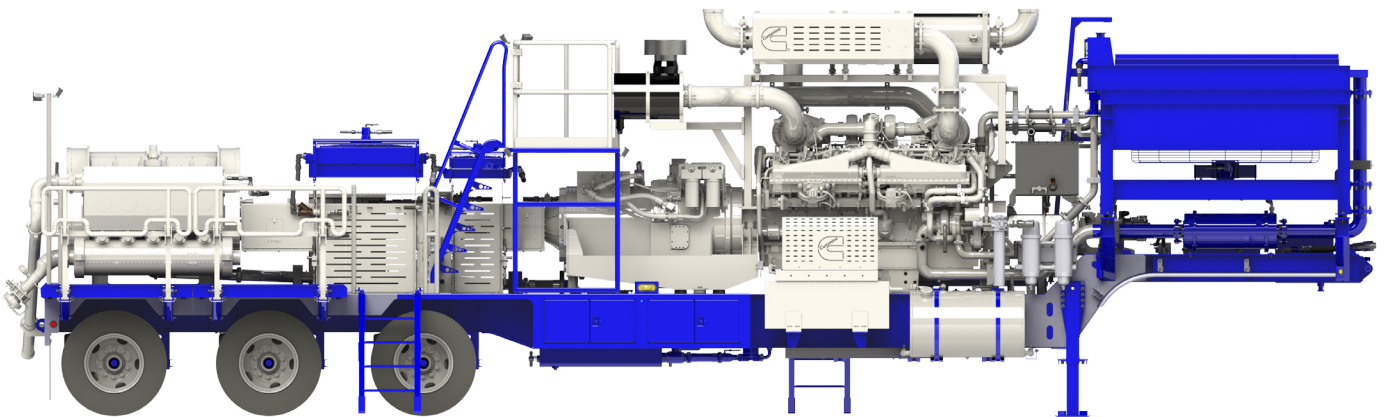

**YOU'RE IN THE BUSINESS OF  
OIL+GAS RECOVERY.**

**WE'RE IN THE BUSINESS OF ENSURING THAT HAPPENS.**

This technically advanced pumping unit combines innovative controls and a design that is geared for ease of operation and serviceability.

Equipment designed by PowerServe Oilfield Equipment.

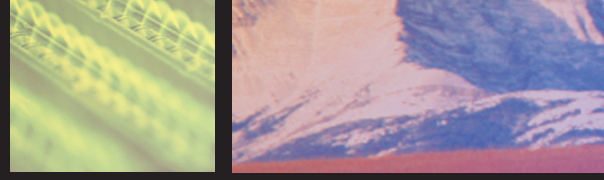

# 2500 HP PUMPER

## SPECIFICATION: PS-FP2500A

UNIT DIMENSIONS	
LENGTH:	44'-9"
WIDTH:	8'-0"
HEIGHT:	13'-2"
WEIGHT:	66,400 lbs.

ENGINE	
MODEL:	Cummins QSK Tier 4 / CAT 3512E
ASPIRATION:	Turbocharged + Aftercooled
CERTIFICATION:	U.S. EPA Tier 4
RATED OUTPUT POWER:	2500 BHP @ 1900 rpm

TRANSMISSION	
MODEL:	TH55-E70 2500 HP
DRIVELINE:	Single GWB 390.65
OUTPUT BREAK:	Built into transmission
COOLING:	Full-flow tube and shell heat exchanger with cold weather bypass

QUINTUPLEX PUMP	
MODEL:	Gardner Denver GD-2500Q
PRESSURE:	MAX: 15,625 psi with 4" plungers
RATE:	17.1 bpm with 4" plungers
FLUID END LUBRICATION:	Graco 24V automatic greasing unit <ul style="list-style-type: none"> <li>• 4 KG reservoir</li> <li>• Operation may be either time based or cycle based</li> </ul>
SUCTION STABILIZER:	Mattco Quint Cellular Suction Stabilization Manifold
DISCHARGE IRON:	Style 50 chicksan with 8 ft. straight joint
MISCELLANEOUS:	Other pumps available upon request.

WORK PLATFORM	
	<ul style="list-style-type: none"> <li>• Pull out maintenance work platform to access quintuplex pump</li> <li>• Permanent maintenance platform for engine air cleaners</li> </ul>

WORK LIGHTS	
	Eight (8) Auxbeam LED work lights will be provided

POWER END LUBE	
PUMP:	Remote mounted Parker PGP365 pump <ul style="list-style-type: none"> <li>• Powered by Parker PGM315 hydraulic motor with flooded inlet</li> </ul>
COOLER:	Dedicated ASA Hydraulic 0929 cooler <ul style="list-style-type: none"> <li>• 140oF Amot thermal valve</li> </ul>
RESERVOIR:	150 gallon aluminum mounted on road side of trailer
FILTER:	20 micron remote mounted

HYDRAULICS	
FAN CIRCUIT:	<ul style="list-style-type: none"> <li>• Pumps: Danfoss Series 90 pump</li> <li>• Motor: Hydro Leduc MA series motor</li> </ul>
OPEN LOOP:	<ul style="list-style-type: none"> <li>• Pumps: Parker PAVC pressure comp</li> <li>• Motor: PE lube pump, hydraulic and oil cooler fans</li> </ul>
RESERVOIR:	56 Gallon aluminum construction
FILTERS:	<ul style="list-style-type: none"> <li>• 10 micron return filter mounted in tank.</li> <li>• 10 micron remote mounted charge pressure filter for closed loop pump</li> </ul>

CONTROLS	
MODEL:	Raptor Oilfield Controls model R-PC
GAUGES:	<ul style="list-style-type: none"> <li>• All system temperatures and pressures monitored by the automatic control system.</li> <li>• Full set of redundant mechanical temperature and pressure gauges for all systems.</li> </ul>
INTERFACE:	Local and remote operation capability with touchscreen interface
MISC.	Other control systems available upon request

Upon request, Artic Fox cold weather kits available for preheat of engine coolant, fuel, power end lube, transmission and hydraulic fluids.